

OG4 50L/Min Oval Gear Meter



The compact rugged OG4 oval gear flowmeter is designed to give high performance with a low cost of ownership. It has a standard flow range from 0.25 to 50 L/min on 30 cSt oil and 2.5 to 50 L/min on water like liquids. It can have totally non-metallic wetted components, PEEK, ceramic and an elastomer which makes this the ideal choice for the metering of aggressive chemicals. The standard inlet and outlet are 3/4" female threads. For OEM use alternatives, including manifold mountings, are available. The standard model is 316 St St with Viton® 'O' ring seal.

At the heart of the meter are a pair of toothed oval gears one of which contains chemically resistant magnets, the gears rotate freely on robust bearings. Rotation is detected through the chamber wall by a Hall effect detector or a reed switch giving approximately 115 pulses per litre passed. The output is an NPN pulse or a voltage free contact closure either of which is readily interfaced with most electronic display or recording devices. This combination of materials and technology ensures a long life product with reliable, accurate operation throughout.



IDEAL FOR

- Engine test
- Oil flow
- High viscosity fluids
- OEM equipment
- Hazardous areas



FEATURES

- Excellent chemical resistance
- Rugged construction
- Individual calibration
- High viscosity capability
- Low pressure loss
- No flow conditioning required
- Compact meter assembly
- Hall, reed switch or Namur sensor
- Accuracy 1.0% reading water
0.5% reading oil (30 cSt)
- ±0.50% reading *
- 0.1% repeatability
- IP67/NEMA 4 protection
- Models to 700 Bar
- Non-metallic option

* When used with our metra-smart instrument

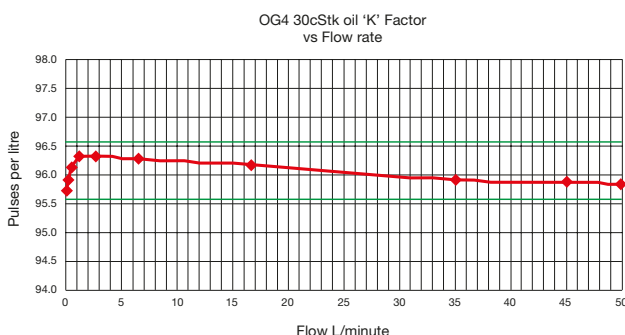

DDM
sensor solutions

The distributor
of your choice!

TITAN ENTERPRISES LTD.
www.flowmeters.co.uk

Distributor: DDM GmbH & Co. KG

Phone: +49 661 967 962-0 >>> Email: info@ddm-sensors.de >>> Web: www.ddm-sensors.de

OG4 50L/Min Oval Gear Meter



Distributor: DDM GmbH & Co. KG

Phone: +49 661 967 962-0 >>> Email: info@ddm-sensors.de >>> Web: www.ddm-sensors.de



Ordering codes

Model	OG4
Body material	S = 316 St St 50 Bar std A = Aluminium 10 Bar max P = PEEK 10 Bar max H = Hastelloy C
Temp rating	S = 80°C / 158°F T = 100°C / 212°F U = 150°C / 300°F
Pressure rating	5 = 50 Bar 750 PSI (St St) 1 = 10 Bar 150 PSI (Al / PEEK) 4 = 400 Bar 5880 PSI (St St) 7 = 700 Bar 10150 PSI (St St)
Seal Material	V = Viton® N = Nitrile E = EPDM P = PTFE (50 Bar max) K = Kalrez®
Detector Type	H = Hall effect R = Reed switch & Resistor N = Namur X = Reed switch (Hazardous area)
Pipe Thread	T = 3/4" (OG4 std)
Connections	B = BSP F N = NPT F F = Flanged (specify)

e.g. **OG4-SS5-VHT-B** is a stainless steel meter rated at 80°C, 50 Bar, Viton® seal, Hall effect detector and a 3/4" BSP thread.



TECHNICAL SPECIFICATIONS

Sample product codes →	Stainless standard OG4-SS5-VHT-B	Aluminium standard OG4-AS1-VHT-B	PEEK standard OG4-PS1-VHT-B
Flow range – Water – 30 cSt Oil	2.5 - 50 L/min 0.25 - 50 L/min	2.5 - 50 L/min 0.25 - 50 L/min	2.5 - 50 L/min 0.25 - 50 L/min
Wetted parts– Body – Gears – Seal – Magnet	316 St St Carbon filled PEEK Viton® Ceramic	Aluminium Carbon filled PEEK Viton® Ceramic	PEEK Carbon filled PEEK Viton® Ceramic
Accuracy – Water – 30 cSt oil	± 1.0% Reading ± 0.5% Reading	± 1.0% Reading ± 0.5% Reading	± 0.5% FSD ± 0.5% FSD
Repeatability	± 0.1%	± 0.1%	± 0.1%
Detector Type	Hall effect	Hall effect	Hall effect
Terminations	Via M20 cable gland	MIL style instrument socket	4 PIN M12 connector
Approx 'K' factor – Pulses/Litre	115	115	115

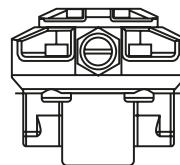
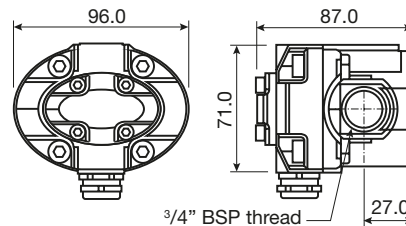

316 St St body

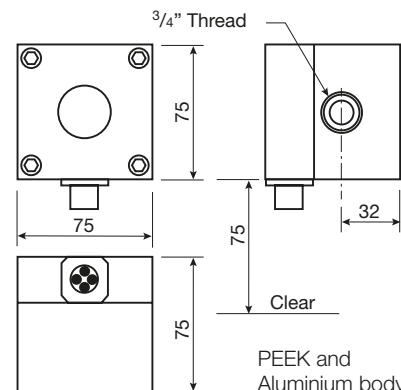

PEEK and Aluminium body

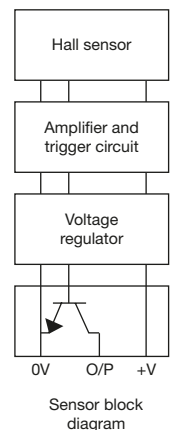
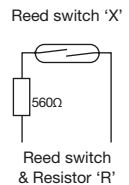
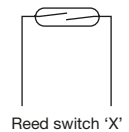

Weight (kg)

St St	50 Bar	1.600
PEEK	10 Bar	0.550
Aluminium	10 Bar	1.000
St St	400 Bar	7.550

TITAN ENTERPRISES LTD.

Coldharbour Business Park, Sherborne, Dorset DT9 4JW

Tel: (44) 01935 812790

Email: sales@flowmeters.co.uk

www.flowmeters.co.uk

For reference only; for latest information contact your local distributor.